



Cascade Series

Model Fifteen Subwoofer

SERVICE MANUAL



Infinity Systems, Inc.
250 Crossways Park Dr.
Woodbury, New York 11797

Rev 1 3/06

- CONTENTS -

BASIC SPECIFICATIONS	1
EXPLODED VIEW/PACKAGING PARTS LIST.....	2
DETAILED SPECIFICATIONS.....	3
CONTROLS AND CONNECTIONS.....	6
OPERATION.....	7
TEST SET UP AND PROCEDURE.....	8
BLOCK DIAGRAM.....	9
ELECTRICAL PARTS LIST (120v)	10
PCB DRAWINGS.....	17
SEMICONDUCTOR PINOUTS.....	20
SCHEMATICS (120v).....	21

Basic Specifications

Cascade Model Fifteen Powered Subwoofer

Frequency Response	32Hz – 150Hz (–3dB) 29Hz – 150Hz (–6dB)
Maximum Amplifier Output	800 Watts RMS (20Hz – 150Hz with no more than 0.1% THD)
Crossover Frequency	50Hz – 150Hz, 24dB/octave, continuously variable (Normal/LFE switch set to “Normal”)
Drivers	Four 6" x 6" (152mm x 152mm)
Dimensions	(H x W x D) 13" x 37" x 8-1/2" (330mm x 940mm x 216mm)
Weight	98 lb (44.5kg)

Infinity continually strives to update and improve existing products, as well as create new ones. The specifications and construction details in this and related Infinity publications are therefore subject to change without notice.

MODEL FIFTEEN EXPLODED/PACKING VIEW

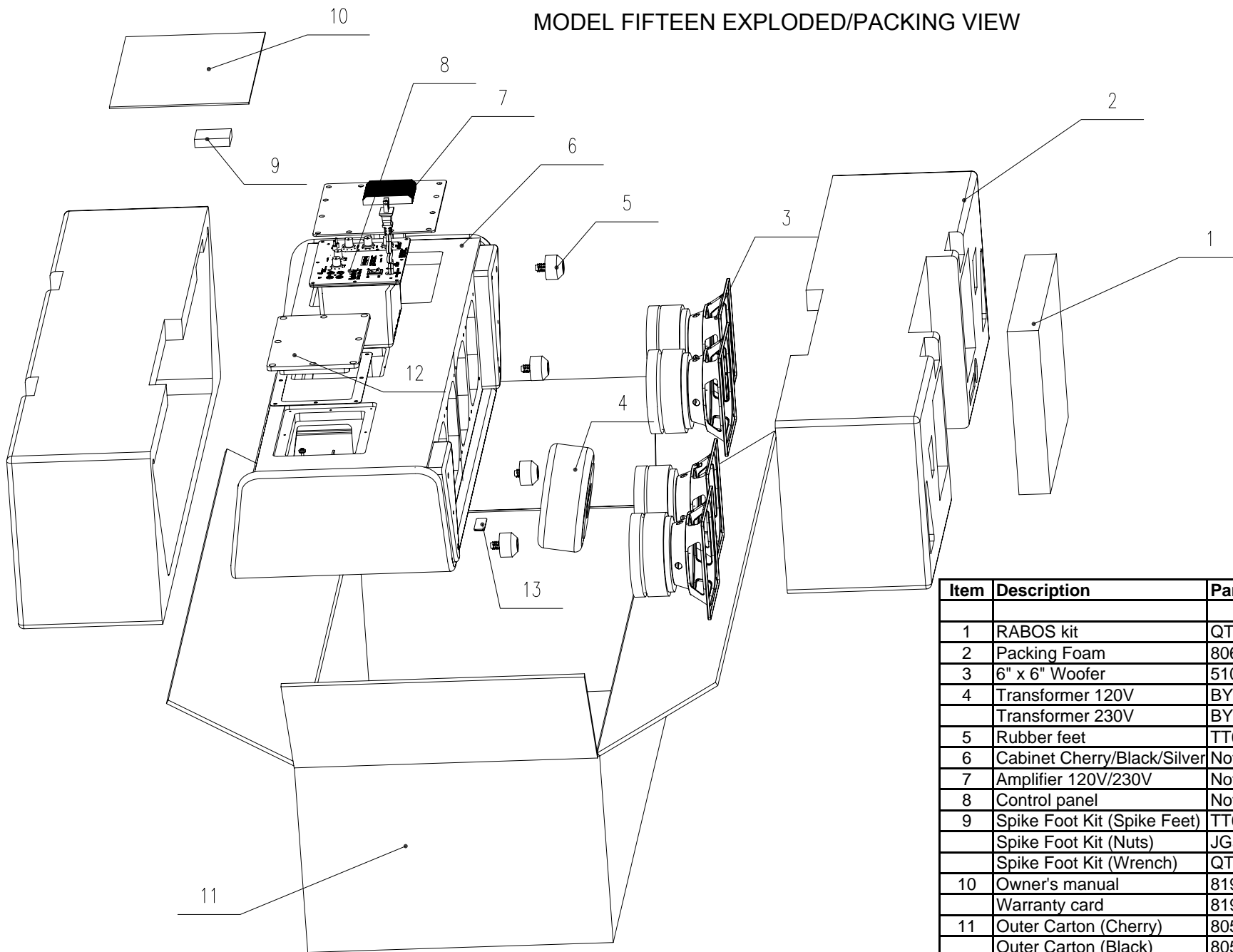

Item	Description	Part Number	Qty
1	RABOS kit	QT0180003010	1 (kit)
2	Packing Foam	806000016530	1 (set)
3	6" x 6" Woofer	510165 11601	4
4	Transformer 120V	BY0152001010	1
	Transformer 230V	BY0152001020	1
5	Rubber feet	TT0035001012	4
6	Cabinet Cherry/Black/Silver	Not For Sale	1
7	Amplifier 120V/230V	Not For Sale	1
8	Control panel	Not For Sale	1
9	Spike Foot Kit (Spike Feet)	TT0012007010	4
	Spike Foot Kit (Nuts)	JG589932	4
	Spike Foot Kit (Wrench)	QT0068002010	1
10	Owner's manual	819001082002	1
	Warranty card	819001082005	1
11	Outer Carton (Cherry)	805001016506	1
	Outer Carton (Black)	805001016507	1
	Outer Carton (Silver)	805001016508	1
12	Access Door	Not For Sale	1
13	Infinity Logo	MP0043001000	1

Cascade Model Fifteen Subwoofer 800W Powered Sub/ Plate Amp

LINE VOLTAGE	Yes/No	Hi/Lo Line	Nom.	Unit	Notes
US 120vac/60Hz	Yes	108-132	120	Vrms	Normal Operation
Parameter	Specification	Unit	QA Test Limits	Conditions	Notes
Amp Section					
Type (Class AB, D, other)	D	---			
Load Impedance (speaker)	4	Ohms		Nominal	Z-curve required
Rated Output Power	800	Watts		Regulated 120 V line	5% tolerance applies
THD@ Rated Power	1	%		22k filter, 50Hz	800W +/- 5%
THD @ 1 Watt	0.5	%		22k filter, 50Hz	
DC Offset		mV-DC	< 20	@ Speaker Outputs	
Damping factor	20	N/A	> 15		measured at 50 Hz
Input Sensitivity					
Line Input	370 mV	mVrms		900 W @ 50Hz	1 input driven
Signal to Noise					
SNR-A-Weighted	100	dBA		relative to rated power	A-Weighting filter
SNR-unweighted	70	dBr		relative to rated power	22k filter
SNR rel. 1W-unweighted	60	dBr		relative to 1W Output	22k filter
Residual Noise Floor	3	mVrms		Volume @max, using RMS reading DMM/VOM (or A/P)	
Residual Noise Floor	3	mVrms(max)		Volume @max, w/ A/P Swept Bandpass Measurement (Line freq.+ harmonics)	
Input Impedance					
Line Input	10 k	ohms		Nominal	
Active Filters					
Low Pass (fixed or variable)					
Frequency	50 - 150 Hz.	Hz			
Slope	24	dB/Octave			
Q	Butterworth	--			
Subsonic filter (HPF)					
Frequency	fixed	Hz			
Slope	33	dB/Octave			
Q	12	--			
Friend Circuit	FIXED	--			
Frequency	80 Hz	Hz			notch filter
Dip	-4	dB			
Q	1	--			
Special filter	RABOS	--			parametric EQ, variable f, Q and notch depth.
Switches					
Main Power ON/OFF					
Type	YES	--			
Type	rocker	--		Located on amp plate	TV-5
Rabos ON/OFF					
Type	YES	--			
Type	mini toggle	--		Located on amp plate	
Polarity Switch					
Type	YES	--		"Off": 0°; "On": 180°	
Type	mini toggle	--		Located on amp plate	
Limiter (yes/no)					
THD at Max. Output Power	YES	--			compressor and limiter
THD at Max. Output Power	less than 10	%		Maximum Output Power	Max THD as a result of limiting.
Output Volume Control					
Volume Control Pot					
Taper (lin/log)	YES	--			mounted on amp panel
@ minimum setting	log A taper	--			
	no output				
Input/Output Configuration					
Line In (L,C,R,AC3,Mono)	Stereo	--		RCA phono jack, gold plated	
LFE In	YES	--		Shared with "R" Line In jack	
Line Outputs (L,C,R)	YES	--			
Hi Level Out	YES	--			
Signal Sensing (ATO)					
Auto-Turn-On (yes/no)					
ATO Input Test Frequency	YES	--			
ATO Input Test Frequency	100	Hz			
ATO Input Threshold	2	mV	typ.		LPF "On", BOS "Off"
ATO Low Pass cutoff	400	Hz	450	ATO-LPF for noise immunity	LPF "On", BOS "Off"
ATO Turn-on time	1	ms	10	Amp connected and AC on, then input signal applied (1 W output)	
Auto Mute / Turn-OFF Time	10	minutes	5 < t < 15	Time before muting, after signal is removed	

Power on Features					
Power on Delay time	greater than 2	sec.			AC Power Applied
Power on LED	YES	--			Bi-color LED located on front of cabinet
Normal On/Off	green / red	color			ATO mode only
ATO	--	color			"Active": green; "Standby": red
Transients/Pops					
ATO Transient	5	mV-peak			@ Speaker Output
Turn-on Transient	30	mV-peak			@ Speaker Output AC Line cycled from OFF to ON
Turn-off Transient	30	mV-peak			@ Speaker Output AC Line cycled from ON to OFF
Efficiency					
Stand-by Input Power	13	Watts	typ.	@ nom. line voltage	
AC Power Cons. @1W	22	Watts	typ.	@ nom. line voltage	
Power Cons. @rated power	1080	Watts	typ.	@ nom. line voltage	Measured is Watts, not VA
Efficiency	74	%	typ.	@ nom. line voltage	
Protection					
Short Circuit Protection	YES	--			Direct short at output
Thermal Protection	YES	--			threshold ~ 65 deg. C at panel
DC Offset Protection	YES	--			DC present at Speaker Out leads Relay for driver/fire protection
Line Fuse Rating (120 V)	6.3	Amps			Type ADL or MDL

CONTROLS AND CONNECTIONS

Rear Panel

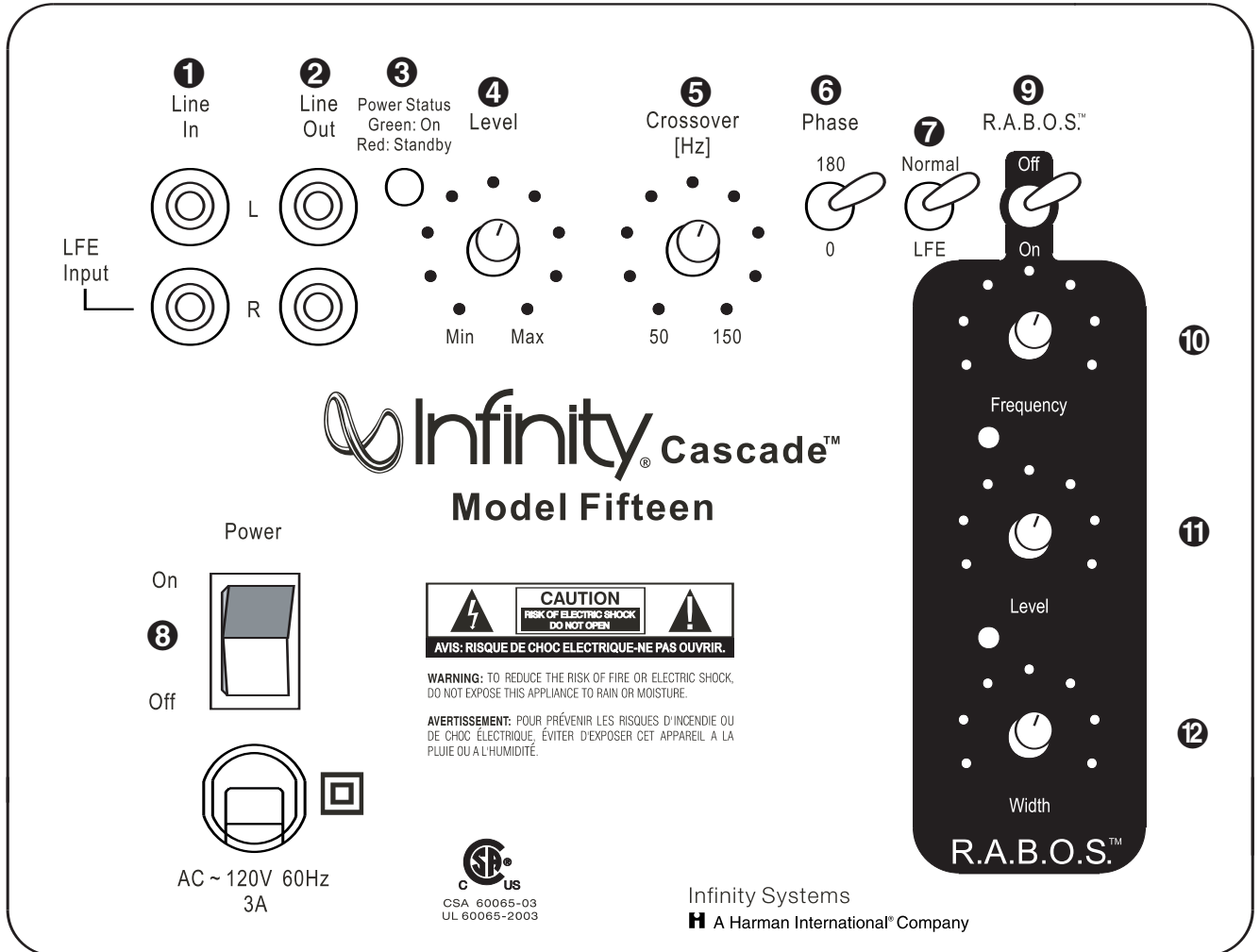

- ❶ Line-Level Inputs
- ❷ Line-Level Outputs
- ❸ Power Indicator
- ❹ Subwoofer Level (Volume) Control
- ❺ Crossover Adjustment
- ❻ Phase Switch
- ❼ Normal/LFE Selector
- ❽ Power Switch

Bass Optimization Controls (see page 5)

- ❹ R.A.B.O.S. Selector
- ❿ Center-Frequency Adjustment
- ⓫ Bass Optimization System Level Adjustment
- ⓬ Bass Optimization System Bandwidth Adjustment

CONNECTIONS

If you have a Dolby® Digital or DTS® receiver/processor with a low-frequency-effects (LFE) output:

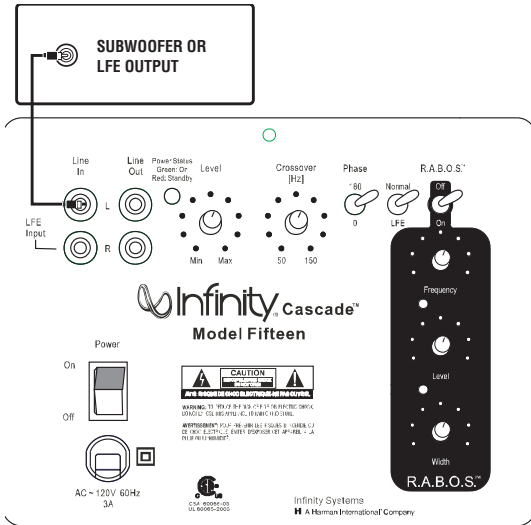

- Set Normal/LFE Switch to LFE.

NOTE: In this case, you do not need to use a Y-connector. Simply connect the LFE output on your receiver/processor to either the left or right input on the subwoofer.

If your receiver/processor has subwoofer outputs for the left and right channels:

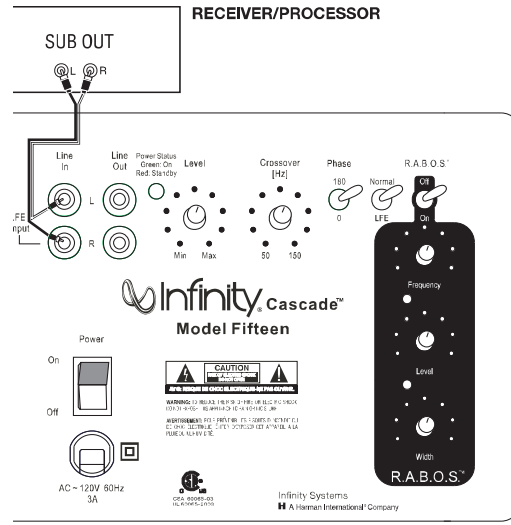

- Set Normal/LFE Switch to Normal.

NOTE: Some receivers have a single subwoofer output (do not confuse this with a single LFE output as described to the left). In that case, it is recommended that you use a Y-connector (not included) to maximize performance.

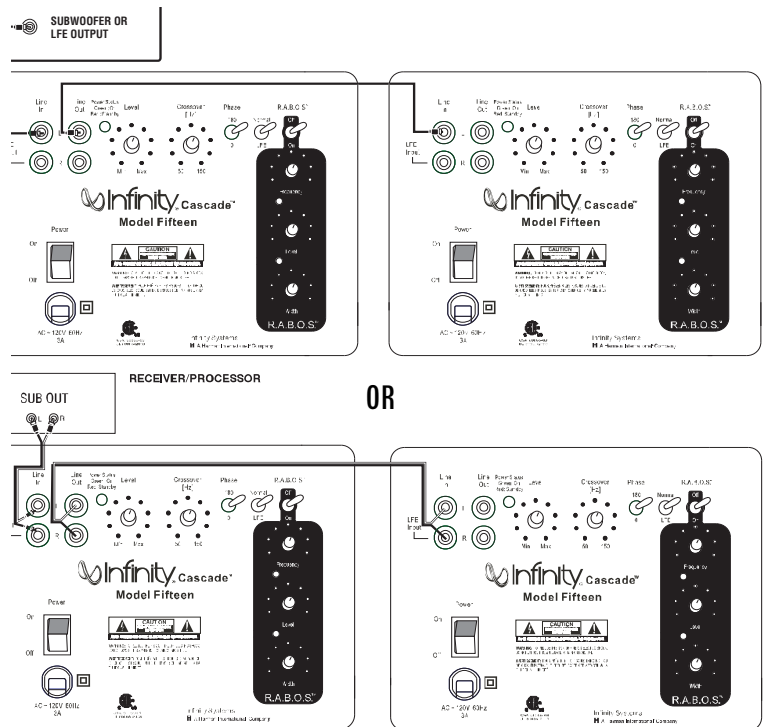

The Cascade Model Fifteen also includes a set of line outputs. These outputs allow you to "daisy-chain" one Model Fifteen to multiple Model Fifteen subwoofers. Simply connect the first subwoofer as described above and then run a subwoofer cable from the line output(s) to the line input(s) on the next sub.

NOTE: This line output is before the R.A.B.O.S. circuit. Each subwoofer's R.A.B.O.S. controls must be individually adjusted during the R.A.B.O.S. setup.

CASCADE MODEL FIFTEEN

OPERATION

Power On

Plug your subwoofer's AC cord into a wall outlet. Do not use the outlets on the back of the receiver.

Initially set the Subwoofer Level (Volume) Control **4** to the "min" position.

Turn on your sub by pressing the Power Switch **8** on the rear panel.

Auto On/Standby

With the Power Switch **8** in the ON position, the Power Indicator LED **3** will remain backlit in red or green to indicate the On/Standby mode of the subwoofer.

RED = STANDBY (No signal detected, Amp Off)

GREEN = ON (Signal detected, Amp On)

The subwoofer will automatically enter the Standby mode after approximately 10 minutes when no signal is detected from your system. The subwoofer will then power ON instantly when a signal is detected. During periods of normal use, the Power Switch **8** can be left on. You may turn off the Power Switch **8** for extended periods of nonoperation, e.g., when you are away on vacation.

Adjust Level

Turn on your entire audio system and start a CD or movie soundtrack at a moderate level. Turn up the Subwoofer Level (Volume) Control **4** about halfway. If no sound emanates from the subwoofer, check the AC-line cord and input cables. Are the connectors on the cables making proper contact? Is the AC plug connected to a "live" receptacle? Has the Power Switch **8** been pressed to the ON position? Once you have confirmed that the subwoofer is active, proceed by playing a CD, record or cassette. Use a selection that has ample bass information.

Set the overall volume control of the preamplifier or stereo to a comfortable level. Adjust the Subwoofer Level (Volume) Control **4** until you obtain a pleasing blend of bass. Bass response should not overpower the room but rather be adjusted so there is a harmonious blend across the entire musical range. Many users have a tendency to set the subwoofer volume too loud, adhering to the belief that a subwoofer is there to produce lots of bass. This is not entirely true. A subwoofer is there to enhance bass, extending the response of the entire system so the bass can be felt as well as heard. However, overall balance must be maintained or the music will not sound natural. An experienced listener will set the volume of the subwoofer so its impact on bass response is always there but never obtrusive.

Crossover Adjustments

NOTE: This control will have no effect if the Normal/LFE Selector Switch **7** is set to "LFE." If you have a Dolby Digital or DTS processor/receiver, the Crossover Frequency is set by the processor/receiver. Consult your owner's manual to learn how to view or change this setting.

The Crossover Adjustment Control **5** determines the highest frequency at which the subwoofer reproduces sounds. If your main speakers can comfortably reproduce some low-frequency sounds, set this control to a lower frequency setting, between 50Hz and 100Hz. This will concentrate the subwoofer's efforts on the ultradeep bass sounds required by today's films and music. If you are using smaller bookshelf speakers that do not extend to the lower bass frequencies, set the Crossover Adjustment Control to a higher setting, between 120Hz and 150Hz.

Phase Control

The Phase Switch **6** determines whether the subwoofer speaker's pistonlike action moves in and out with the main speakers (0°) or opposite the main speakers (180°). Proper phase adjustment depends on several variables such as room size, subwoofer placement and listener position. Adjust the Phase Switch to maximize bass output at the listening position.

Cascade Model Fifteen TEST PROCEDURE

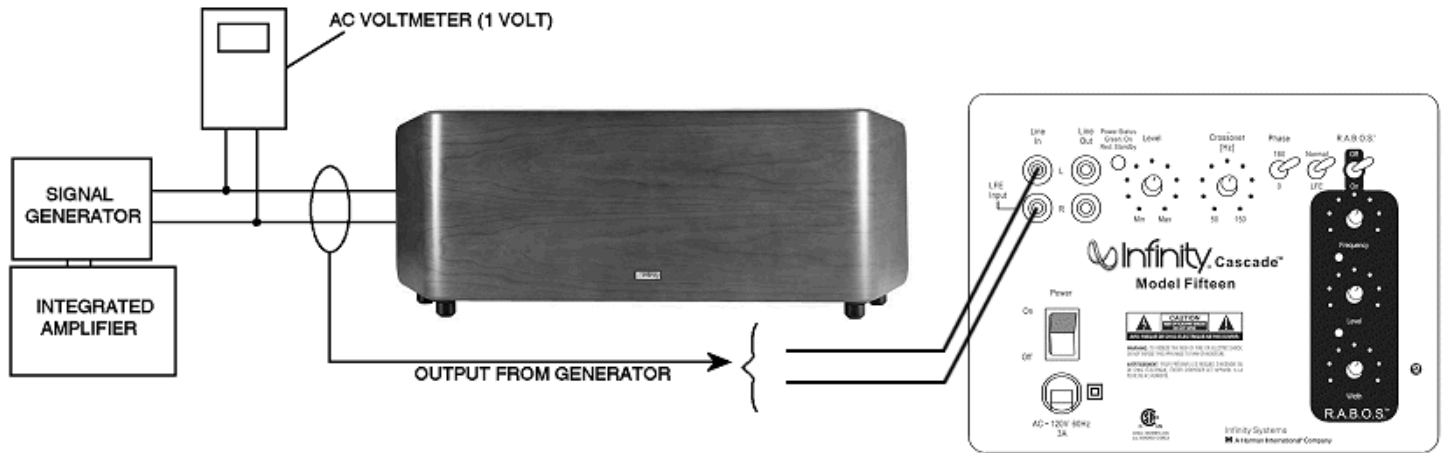

The operation of the Cascade Model Fifteen subwoofer, and the proper settings for the Room Adaptive Bass Optimization System, or R.A.B.O.S., is thoroughly covered in the Owner's manual. For service purposes, the R.A.B.O.S. system is canceled when all three front panel controls (F) (L) (W) are turned fully CW (Clockwise), or if the R.A.B.O.S. On/Off switch is OFF. The only other control of concern is the Main Level Control on the front panel, which operates like a traditional potentiometer.

Equipment needed:

- Function/signal generator/sweep generator
- Integrated Amplifier
- Multimeter
- RCA cables; Speaker cables

General Unit Function (UUT = Unit Under Test)

Switch/Controls:

MAIN LEVEL control full Counterclockwise (Min)
 CROSSOVER (Hz) Full Clockwise (150)
 R.A.B.O.S. On/Off switch OFF
 PHASE switch - either position
 (3) R.A.B.O.S. controls – do not matter

- 1) From the signal generator, connect one line level (RCA) cable to the Line In jacks (L/R) on the UUT. Use a Y-cable from a mono source if necessary to connect to both inputs.
- 2) Turn on generator; adjust to **100mV, 50 Hz**.
- 3) Plug AC power cord in UUT, turn power switch ON.
- 4) LED should be ON (faceplate). Turn up LEVEL control to full Clockwise (Max).
- 5) LED should be Green; Bass response should be heard and felt from woofer at bottom of cabinet.
- 6) Turn LEVEL control full Counterclockwise (Min). Turn power switch OFF.

Sweep Function

- 1) Follow steps 1-5 above, using a sweep generator as a signal source – adjust the generator to **75mV, 50 Hz**.
- 2) Sweep generator from 20Hz to 300Hz. Listen for any rattles, clicks, buzzes or any other noises. If any unusual noises are heard, test woofer according to the instructions below.

Driver Function

- 1) Remove woofer from the enclosure.
- 2) Check DC resistance of woofer; it should be **3.7Ω ±10%**,
- 3) Connect a pair of speaker cables to woofer terminals. Cables should be connected to an integrated amplifier fed by a signal generator. Turn on generator and adjust so that speaker level output is **6.0V**.
- 4) Sweep generator from 20Hz to 1kHz. Listen to driver for any rubbing, buzzing, or other unusual noises.

Model Fifteen

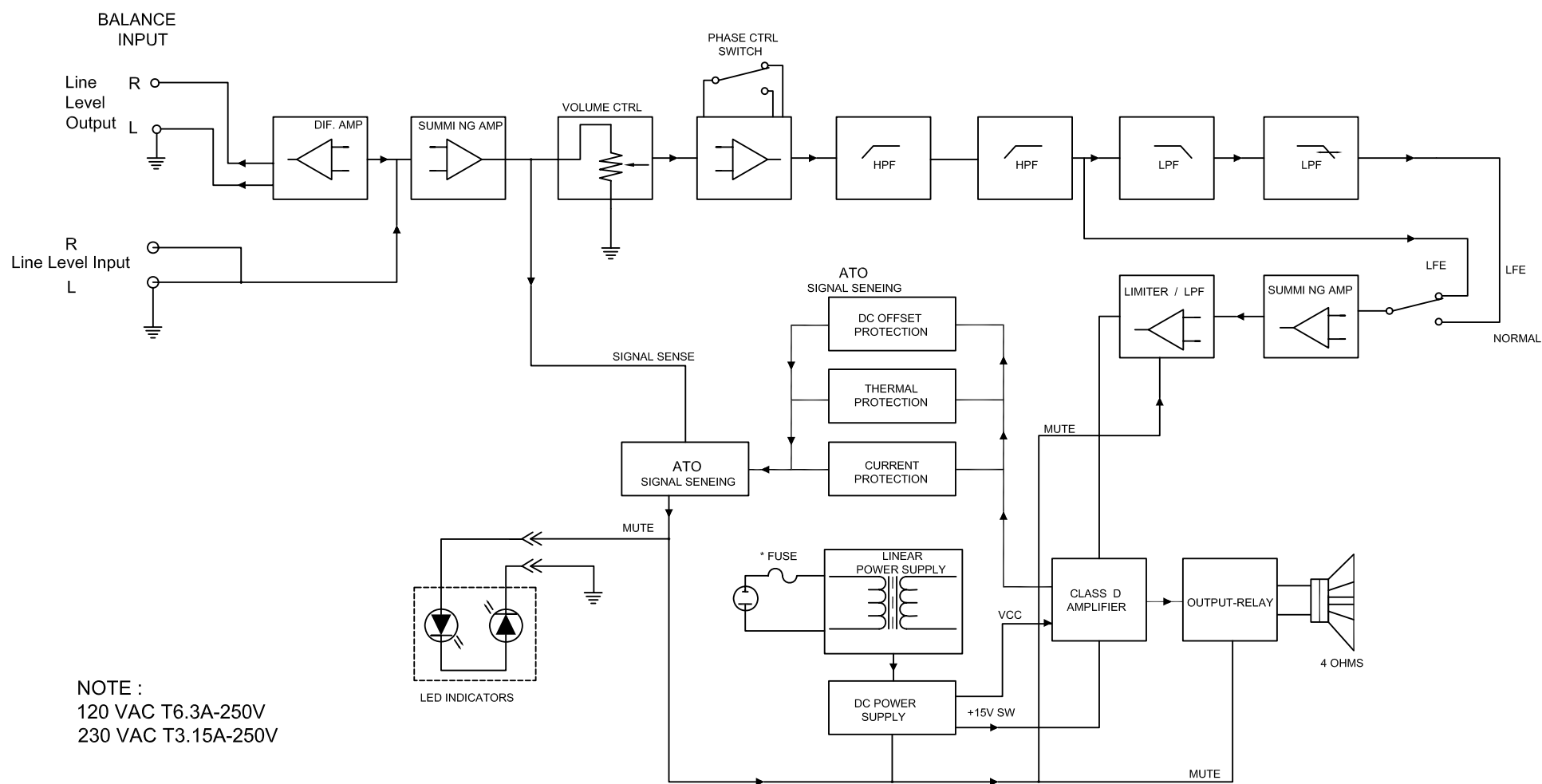

NOTE :
 120 VAC T6.3A-250V
 230 VAC T3.15A-250V

Designed by 製圖	Checked by 檢圖	Approved by 核准	Model No. 型號	Issue No./文件號碼
			Cascade Model 15	2005/10/31
				376

Cascade Model Fifteen Electrical Parts List				
Part Number	Description		Q'ty	Reference Designator
MAIN BD				
<i>Resistors</i>				
020-120401-120ZS	GS carbon film resistor	1K2 1W J TAP	1	R6
024-000097-120ZS	GS SMD resitor PN:1206	0R 1/4W J 12	1	D31
024-100498-121ZS	GS SMD resistor	1K 1/4W J 12	2	R119,121
024-100598-121ZS	GS SMD resistor	10K 1/4W J 1	13	R1,4,7,16,122,123,126,128,138,165,168,170,125,
*024-100698-121ZS	GS SMD resistor	100K 1/8W J	1	R120
024-130598-120ZS	GS SMD resistor	13K 1/8W J 0	2	R118,169,
024-150598-100ZS	GS SMD resistor	15K 1/8W F 0	2	R20,21
024-220298-121ZS	GS SMD resistor	22R 1/4W J 1	2	R28,29
024-220498-120ZS	GS SMD resistor	2K2 1/4W J 1	4	R17,31,110,139
024-220597-120ZS	GS SMD resistor	22K 1/4W J 1	1	R127
024-232497-100ZR	GR SMD resistor	2K32 1/4W F	2	R189,192,
024-332497-100ZS	GS SMD resistor	3K32 1/4W F	1	R22
024-332598-100ZS	GS SMD resistor	33K2 1/4W F	2	R60, 60B
024-470298-120ZS	GS SMD resistor	47R 1/8W J 0	4	R24-27
024-470398-120ZS	GS SMD resistor	470R 1/8W J	4	R145,155,177,186
024-470598-121ZS	GS SMD resistor	47K 1/4W J 1	2	R3,171
024-560497-120ZS	GS SMD resistor	5K6 1/4W J 1	1	R30,
024-560598-121ZS	GS SMD resistor	56K 1/4W J 1	1	R15
024-590498-100	SMD resistor	5K9 1/8W F 0	1	R63
024-680498-121ZS	GS SMD resistor	6K8 1/4W J 1	2	R23,19
021-100403-020ZS	GS MOF resistor	1K/3W J TAPI	2	R173, 48
022-005105-020ZS	GS resistor	0R05 ohm 5W	1	R2
<i>Capacitors</i>				
034-100614-301ZR	GR electrolytic cap. 105°C	100uF/16V M	1	C117
034-100615-307ZR	GR electrolytic cap.	100uF/16V M	1	C62
034-100625-300ZS	GS electrolytic cap.	100uF/25V M	1	C8
034-220525-300ZR	GR electrolytic cap.	22uF/25V M	2	C25,26
034-220625-300ZS	GS electrolytic cap.	220uF/25V M	1	C100
031-100143-101ZS	GS SMD cap.	0u01/50V 120	2	C27,28
031-100144-103ZS	GS SMD cap.	0u001/50V K	1	C130
031-100344-100ZS	GS SMD cap.	0u1/50V K 08	1	C116
031-100364-100ZS	GS SMD cap.	0u1/100V K 1	5	C69,112,115,135,138,
031-100384-100RZS	GS SMD cap.	0u1/250V K 1	3	C39B,5,6
031-220344-300ZS	GS SMD cap.	220pF/50V K	1	C40
031-470144-101ZS	GS SMD cap.	0u0047/50V K	1	C1G1
031-470344-100ZS	GS SMD cap.	470pF/50V K	1	C123
032-100484-200ZS	GS END mylar cap.	1uF/250V K P	3	C30,37,39
033-330494-271ZS	GS NPE capacitor	3u3/63V K10	2	C114,137
033-680464-272ZS	GS NPE capacitor	6u8/100V K10	2	C113,136
034-330795-204ZR	GR electrolytic cap. 105°C	3300uF/80V	4	C1,4,1A,4A
034-100715-204ZR	GR electrolytic cap. 105°C	1000uF/16V M	2	C109,132
034-330615-200ZR	GR electrolytic cap. 105°C	330uF/16V M	1	C32

Part Number	Description		Q'ty	Reference Designator
MAIN BD				
<i>Semiconductors</i>				
051-290700-100ZR	GR transistor PNP (ON)	PN:MPS2907A	4	Q12,14,16,18
051-540101-000ZR	GR transistor PNP(FAIR	PN:2N5401 TO	1	Q3
054-000100-100ZS	GS SMD DIODE:	PN:ES1D 200V	5	D23,37,40,44,47
054-008409-000ZR	GR SMD ZENZER DIODE	PN:BZX84C3V0	1	D32
054-033904-100	SMD transistor	PN:MMBT3904L	7	Q28,29,50,51,127,128,130,
054-033906-100ZR	GR SMD transistor	PN:MMBT3906L	2	Q30,38,
054-290701-100	SMD transistor (ON)	PN:MMBT2907A	1	Q52
054-414803-100ZS	GS SMD DIODE:	PN:LL4148 MI	14	1,4,5,6,21,22,33,34,38,41,45,48,53,54
054-540100-100	SMD transistor (PNP)	PN:MMBT5401	3	Q1,2,26
054-555100-100ZR	GR SMD transistor (NPN	PN:MMBT5551	1	Q25
051-002301-000ZR	GR MOSFET N CHANNEL	PN:FB23N20D	4	Q11,13,15,17
<i>Miscellaneous</i>				
044-100100-000ZS	GS SMD FERRITE BEAD	PN:321611 60	2	FB1,2
043-110300-000ZR	GR COIL	PN:YT-13141	1	L8
*043-300101-000ZR	GR INDUCTOR	PN:YT-10033	2	L9,10
043-560200-000ZR	GR INDUCTOR	56uH YT-1077	1	L12
072-040007-000ZS	GS terminal house SWA101	PN:JS-1001-0	1	P9
072-040008-110ZS	GS terminal house	PN:JS-1001-0	1	P1
072-040063-000ZS	GS terminal (PCB TYPE)	PC205 t=0.5	4	TER5,6,SPKRA2,SPKRB2
072-040064-000ZR	GR terminal (PCB TYPE)	PC250 t=0.8	3	SPKRA1,SPKRB1,TER7,
073-111003-000ZR	GR shorting strap	54.9x13.6x1m	1	J7
073-111004-000ZR	GR shorting strap	29.5x12.4x0.	1	J9
074-300043-000	RELAY	PN:TRL-48VDC	1	RLY1
008-061215-000ZR	GR GASKET C4305	12x15 t=5mm	1	
008-061902-022ZS	GS GASKET psa	187.6x15 t=1	2	AMP.PLATEx2
008-062702-002ZS	GS GASKET UL94HF-1	t=1mm	2	
025-010300-000ZR	GR thermister	PN:NTSE103KZ	1	TH1
025-233100-000ZR	GR thermister	PN:PTMS2331R	1	TH2
082-021675-002ZR	GR Wire set #16 UL1015	L=750mm+550mm Org	1	speak output used
082-021675-000ZR	GR Wire set #16 UL1015	L=750mm+550mm Blk	1	speak output used
082-021675-001ZR	GR Wire set #16 UL1015	L=750mm+550mm Red	1	speak output used
082-021675-003ZR	GR Wire set #16 UL1015	L=750mm+550mm Purple		speak output used
DRIVER BD				
<i>Resistors</i>				
024-000097-120ZS	GS SMD resistor PN:1206	0R 1/4W J 12	4	R313,314,318,320
024-100297-120ZS	GS SMD resistor	10R 1/4W J 1	4	R89,90,140,150
024-100497-100ZS	GS SMD resistor PN:1206	1K 1/4W F 12	10	R81,85,96,97,131,137,142,147,162,179
024-100598-101ZS	GS SMD resistor PN:1206	10K 1/4W F 1	12	R75,82,83,92,98,132,133,151,156,163,164,183
024-110598-100ZS	GS SMD resistor	11K 1/8W F 0	2	R74,99
024-200597-100ZS	GS SMD resistor PN:1206	20K 1/4W F 1	4	R95,141,148,181
024-220397-120ZS	GS SMD resistor	220R 1/4W J	2	R136,167
024-220498-120ZS	GS SMD resistor	2K2 1/4W J 1	1	R134
024-220598-121ZS	GS SMD resistor	22K 1/4W J 1	1	R37

Part Number	Description		Q'ty	Reference Designator
DRIVER BD				
024-220798-121ZS	GS SMD resistor	2M2 1/4W J 1	2	R87,93
024-274497-100ZS	GS SMD resistor	2K74 1/4W F	3	R80,84,157
024-390498-121ZS	GS SMD resistor	3K9 1/4W J 1	2	R130,161,
024-390598-100ZS	GS SMD resistor	39K 1/4W F 1	2	R86,94
024-470397-120ZS	GS SMD resistor	470R 1/4W J	1	R91
024-470498-121ZS	GS SMD resistor	4K7 1/4W J 1	4	R34,36,152,153
024-470598-121ZS	GS SMD resistor	47K 1/4W J 1	1	R35
024-470697-120ZS	GS SMD resistor	470K 1/4W J	2	R32,33
024-560598-121ZS	GS SMD resistor	56K 1/4W J 1	1	R38
024-680498-121ZS	GS SMD resistor	6K8 1/4W J 1	2	R135,166
<i>Capacitors</i>				
031-100244-101ZS	GS SMD cap.	0u01/50V K 1	4	C108,118,131,140
031-100343-101	SMD cap.	100pF/50V J	2	C81,84
031-100344-102AZS	GS SMD resistor	0u1/50V K 12	6	C75-78,82,85
031-180344-100ZS	GS SMD cap.	0u18/50V K 0	2	C80,83
031-470244-101	SMD cap.	0u047/50V K	4	C93,94,101,124
031-560243-100ZS	GS SMD cap.	56pF/50V J 0	4	C92,102,105,125
031-560343-101FZR	GR SMD cap.	560pF/50V J	1	C79
<i>Semiconductors</i>				
051-222200-100ZR	GR transistor NPN (ON	PN:MPS2222AR	2	Q20, 22
051-555100-000ZR	GR transistor NPN	PN:2N5551 TO	2	Q21,23
051-000600-100	transistor NPN	MPSW06RLRA T	1	Q31
053-211100-000	IC:DIP,HALF-BRDG DRIVER	PN:IR2111 8P	2	U7,8
054-000100-100ZS	GS SMD DIODE:	PN:ES1D 200V	2	D35,43
054-001002-100	SMD ZENER DIODE 10V	PN:BZX84C10	2	D42,49
054-005501-100	SMD ZENER DIODE 3.6V	PN:BZV55C3V6	1	D60
054-007200-100LZS	SMD IC, DUAL OP-AMP:(JRC)	PN:M072M-TE1	2	U9,10
054-033906-100	SMD transistor	PN:MMBT3906L	2	Q34,35
054-050601-100	SMD ZENER DIODE 5.6V	PN:BZX84C5V6	2	Z7,8
054-414803-100ZS	GS SMD DIODE:	PN:LL4148 MI	5	D36,39,46,52,61
054-540100-100	SMD transistor (PNP)	PN:MMBT5401	2	Q33,40
054-555100-100ZR	GR SMD transistor (NPN	PN:MMBT5551	1	Q32
<i>Miscellaneous</i>				
072-040229-000	HEADER Right Angle	PN:211-107-0	1	PIN2
072-040230-000	HEADER Right Angle	PN:211-111-0	1	PIN1
061-700044-000ZR	GR mica	13x18mm TO-2	2	Q13,17
061-700090-900ZR	GR ceramic washer	16x21mm t=2m	2	11,15
063-010010-000ZR	GR bracket for transistor	P/N:TRK-2	5	Q11,13,15,17,TH1
063-272200-000ZR	GR AMP.PLATE(MODEL	265.9x215.1	1	
073-014103-500ZR	GR Bracket (HB5000)	6.64"x3.5"x3	1	
073-032153-600ZS	GS Heatsink	120x85x20mm	1	AMP,PLATE

Part Number	Description		Q'ty	Reference Designator
LIMIT BD				
021-232497-100ZR	GR metal film resistor	2K32 1/4W F	2	R189,192
021-392597-100ZR	GR metal film resistor	39K2 1/4W F	2	R187,190
050-414802-100ZR	GR diode :DIP	PN:1N4148 TA	2	D90,91
051-390400-100ZR	GR transistor NPN (ON	PN:2N3904G T	1	Q37
051-390600-100ZR	GR transistor PNP (ON	PN:2N3906G T	1	Q36
082-042615-000	Wire set #26 UL1007	L=145mm Red/Org/Yel/Blue		
CONTROL BD				
<i>Resistors</i>				
020-000098-400ZS	GS Carbon film resistor	0R 1/8W TAPI	4	C211,217,219,226
021-124698-100ZS	GS MF resistor	124K 1/8W F	1	R214
021-340498-100ZS	MF resistor	3K40 1/8W F	1	R204
024-100498-121ZS	GS SMD resistor	1K 1/4W J 12	2	R238,264,
024-100598-100ZS	GS SMD resistor	10K 1/4W J 1	11	R202,206,27,212,222,235,252-254,257,282,
024-100798-101ZS	GS SMD resistor	1K5 1/4W J 1	1	R251
024-150598-100ZS	GS SMD resistor	15K 1/8W F 0	1	R223,
024-200598-121ZS	GS SMD resistor	20K 1/4W J 1	2	R256,286,
024-205597-100ZS	GS SMD resistor	20K5 1/4W F	1	R229
024-220298-121ZS	GS SMD resistor	22R 1/4W J 1	1	R249
024-226598-100ZS	GS SMD resistor	22K6 1/4W F	4	R208,209,231,232
024-261697-100ZS	GS SMD resistor	261K 1/4W F	1	R228
024-270498-121ZS	GS SMD resistor	2K7 1/4W J 1	1	R237
024-274497-100ZS	GS SMD resistor	2K74 1/4W F	1	R258
024-301597-100ZS	GS SMD resistor	30K1 1/4W F	2	R260,224,
024-330397-120ZR	GR SMD resistor	330R 1/4W J	2	R284,285
024-330498-121ZS	GS SMD resistor	3K3 1/4W J 1	2	R240,287,
024-332598-100ZS	GS SMD resistor	33K2 1/4W F	2	R220,225
024-470698-121ZS	GS SMD resistor	470K 1/4W J	1	R259
024-470797-100ZS	GS SMD resistor	4M7 1/4W F 1	2	R244,243
024-475598-101	SMD resistor	47K5 1/4W F	2	R280,283,
024-510398-121ZS	GS SMD resistor	510R 1/4W J	1	R261
024-549597-100ZS	GS SMD resistor	54K9 1/4W F	1	R230
024-620398-121ZS	GS SMD resistor	620R 1/4W J	4	R221,226,289,290,
024-680498-121ZS	GS SMD resistor	6K8 1/4W J 1	1	R247
024-680598-121ZS	GS SMD resistor	68K 1/4W J 1	1	R250
024-750597-120ZS	GS SMD resistor	75K 1/4W J 1	1	R299
024-820598-121ZS	GS SMD resistor	82K 1/4W J 1	1	R263
024-820698-100ZS	GS SMD resistor	820K 1/8W J	1	R288,
026-500495-003	VR 5k ohm LEVEL CONTROL	PN:16K11-A5K	1	R216
026-500595-267ZS	GS VR 50KBx4 CROSSOVER	PN:RD1631411	1	R233
<i>Capacitors</i>				
032-390143-300ZS	GS Mylar capacitor	0u0039/50V J	1	C281,
034-100515-304ZS	GS Electrolytic cap.	10uF/16V M	1	C220
034-100615-301ZS	GS Electrolytic capacitor	100uF/16V M	1	C221
034-220516-301ZS	GS electrolytic capacitor	22uF/16V M	3	C223,225,236
034-220525-300ZR	ESK Capacitor	0u001/100V J	1	C202

Part Number	Description		Q'ty	Reference Designator
CONTROL BD				
035-100293-300ZR	GR Mylar capacitor (ESK TY	0u01/63V J P	3	C212,224,280,
035-220353-302	ESK Capacitor ESK063P22J	0u22/63V J P:5m/m	2	C207,C208
035-270293-300	PE Capacitor PN:ESK063S3	0u033/63V J	2	C209,218
035-680253-300	PE capacitor FE-M PN:ESK	0u068/63V J	2	C201,213
035-680353-300ZR	GR ESK capacitor	0u68/63V J P	1	C214
031-100344-102AZS	GS SMD capacitor	0u1/50V K 12	8	C227,229,230,232-235,16,
031-100344-104AZS	GS SMD capacitor	100pF/50V K	1	C222
031-220243-103ZS	GS SMD capacitor	0u022/50V J	1	C2G1
031-220344-106AZS	GS SMD capacitor	220pF/50V K	4	C215,216,228,231
<i>Semiconductors</i>				
054-003900-100	SMD ZENER DIODE	PN:RLZ3.9B 3	1	D202,
054-007200-100LZS	SMD IC, DUAL OP-AMP:(JRC)	PN:M072M-TE1	8	U200-206,301
054-011400-100ZR	GR SMD Transistor	PN:DTC114TKA	1	Q202
054-414803-100ZS	GS SMD DIODE:	PN:LL4148 MINI-MELF	8	D201,204,207,209,212,216,218,219
050-505200-001ZS	GS LED	PN:LT-2402-2	1	LED1
051-011100-100	JFET N-Channel	PN:J111 TO-9	1	Q200
<i>Miscellaneous</i>				
008-060805-022ZS	GS HS770(a) UL94HBF	foam gasket w/ adhesive	1	wrapped around the wire set
073-010021-000ZR	GR screw fitting base	vibration.	2	T1,2,
008-061201-012ZS	GS GASKET psa	115x10 t=1.0	4	COVERx2,PLATEx2
008-061701-012ZS	GS GASKET psa	173.3x10 t=1	4	COVERx2,PLATEx2
072-010315-000ZR	GR RCA JACK	4P PN:0504000R1G	1	J201
072-040007-000ZS	GS terminal house SWA101	PN:JS-1001-0	3	P3,4,8
074-030002-000ZR	TOGGLE SW RABOS,PHASE,LFE	PN:L101-T2B4	3	SW200,201,202
POWER BD				
<i>Resistors</i>				
024-100598-101ZS	GS SMD resistor PN:1206	10K 1/4W F 1	4	R409,416,417,405
024-120597-120ZS	GS SMD resistor	12K 1/4W J 1	2	R413,415
024-220498-120ZS	GS SMD resistor	2K2 1/4W J 1	1	R400
024-330598-121ZS	GS SMD resistor	33K 1/4W J 1	3	R406,408,414
024-470398-121ZS	GS SMD resistor	470R 1/4W J	2	R401,402
<i>Capacitors</i>				
034-220516-301ZS	GS Electrolytic capacitor	22uF/16V M	5	C14,15,411,415,416
035-100464-300	ESK Mylar capacitor	1u/100V K P:	2	C425,426
034-220625-300ZS	GS Electrolytic capacitor	220uF/25V M	2	C414,413
034-330625-300ZS	GS Electrolytic capacitor	330uF/25V M	1	C412
034-470415-300ZS	GS electrolytic capacitor	4u7/50V M R	1	C407
034-470515-200ZR	GR electrolytic capacitor	47uF/16V M	2	C408,237
031-100244-101ZS	GS SMD capacitor	0u01/50V K 1	5	C404-406,12,13
031-100384-100RZS	GS SMD capacitor	0u1/250V K 1	2	C428,429
032-100484-200ZS	GS END mylar capacitor	1uF/250V K P	3	C410,418,427
034-330795-204ZR	GR electrolytic cap 105°C	3300uF/80V	8	C420-423,420A-423A

Part Number	Description		Q'ty	Reference Designator
POWER BD				
031-100344-102AZS	GS SMD capacitor	0u1/50V K 12	4	C417,401,402,403
<i>Semiconductors</i>				
050-013000-100	DIODE TVZ:DIP	PN:P6KE130A	1	D404
051-000600-100	Transistor NPN	MPSW06RLRA T	1	Q406
051-005600-100ZR	GR transistor PNP	PN:MPSW56RLR	1	Q408
054-000100-100ZR	GR GS SMD DIODE:	PN:ES1D 200V	4	D406, 407, 408, 409
054-001501-100	SMD ZENER DIODE 15V	PN:BZX84C15	3	D400,402,403
054-390402-100ZR	GR SMD Transistor	PN:MMBT3904T	3	Q402,203,204
054-414803-100ZS	GS SMD DIODE:	PN:LL4148 MINI-MELF	3	D405, D413, D414
053-010200-000	IC:DIP PWM SWITCH	PN:TOP102YAI	1	U400
051-003100-000ZS	GS transistor NPN	PN:TIP 31C T	1	Q404
052-150400-000ZR	GR bridge rectifier	PN:GBJ1504	1	BR400
<i>Miscellaneous</i>				
044-100100-000ZS	GS SMD FERRITE BEA	PN:321611 60	3	FB403-405
044-100103-000	SMD FERRITE BEAD	PN:321611 80	1	FB406
042-010115-000ZR	GR transformer	PN:YT-13167	1	T400
043-560200-000ZR	GR INDUCTOR	56uH YT-1077	1	L400
072-040039-000ZR	GR terminal (PCB TYPE)	PC205 t=0.8	8	TER402,403,406,407,TER2,4,8,3
072-040064-000ZR	GR terminal (PCB TYPE)	PC250 t=0.8	3	TER401,404,TER1
072-040008-110ZS	GS terminal base	PN:JS-1001-0	1	P2
RABOS BD				
<i>Resistors</i>				
035-330293-300	GS SMD resistor PN:1206	0R 1/4W J 12	3	R302,303,297
024-100398-101ZS	GS SMD resistor	100R 1/8W F	1	R339
024-100498-100ZS	GS SMD resistor	1K 1/8W F 08	2	R363,384,
024-100598-100ZS	GS SMD resistor	10K 1/8W F 0	9	R338,342,343,346,348,353,355,361,368,
024-100598-121ZS	GS SMD resistor	1M 1/8W F 08	1	R356,
024-100898-100ZS	GS SMD resistor	10M 1/8W F 0	1	R362
024-110698-100ZS	GS SMD resistor	110K 1/8W F	1	R347
024-120598-100ZS	GS SMD resistor	12K 1/8W F 0	2	R354,369
024-137698-100ZS	GS SMD resistor	137K 1/8W F	1	R383
024-158398-100ZS	GS SMD resistor	1K5 1/8W F 0	1	R341
024-237598-120ZS	GS SMD resistor	23K7 1/8W F	2	R380,281
024-267498-100ZS	GS SMD resistor	2K67 1/8W F	1	R336
024-340398-100ZS	GS SMD resistor	340R 1/8W F	2	R357,371
024-357498-100ZS	GS SMD resistor	3K57 1/8W F	1	R335
024-374498-100ZS	GS SMD resistor	3K74 1/8W F	1	R385,
024-523498-100ZS	GS SMD resistor	5K23 1/8W F	2	R381,382,
024-549398-100ZS	GS SMD resistor	549R 1/8W F	1	R344
024-619498-100ZS	GS SMD resistor	6K19 1/8W F	2	R359,374
024-680398-100ZS	GS SMD resistor	680R 1/8W F	1	R360
024-787398-100ZS	GS SMD resistor	787R 1/8W F	2	R350,364
024-931498-100ZS	GS SMD resistor	9K31 1/8W F	1	R351
026-100595-001ZS	VR 10KAx2 RABOS WID,LEV	XV012311YGPJ	2	VR302,303

Part Number	Description		Q'ty	Reference Designator
RABOS BD				
026-100595-002ZS	VR 10KCx2 RABOS FREQ	XV012311YGPJ	1	VR301
<i>Capacitors</i>				
034-220525-300ZR	GR Electrolytic capacitor	22uF/25V M	2	C303,304,
035-100163-300	GR PE Capacitor	0u1/100V J P	3	C322,323,328
035-220353-302	Mylar capacitor (ESK TYPE)	0u027/63V J	1	C380
035-100363-300ZR	GR PE Capacitor	0u1/100V J P	3	C322,323,328
035-680253-300	PE capacitor FE-M PN:ESK	0u068/63V J	1	381,
031-100344-102AZS	GS SMD capacitor	0u1/50V K 12	2	C305,306
<i>Semiconductors</i>				
054-007400-100ZR	GR SMD IC:(OP)	PN:TL074CDR	1	U300
EMI BD & MISC. MECH.				
080-060351-009ZS	GS copper wire	φ0.6x63m/m	1	J1,
025-006000-000	Thermister	P/N:CL-60	1	TH3
039-220384-100ZR	GR X2 Safety cap 0u22	PN:HQX0.22K2	2	CXAC1,CXAC2
043-155300-000ZR	GR COIL	PN:YT-13192	1	L7
*043-324300-000ZR	GR INDUCTOR	324uH YT-107	1	L13
073-050001-000ZS	GS FUSE CLIP	P/N:CFFH1206	2	F1,B1
061-001052-000ZS	GS knob w/white indicator	PN:49001-W	2	for R216,233
061-016001-000	Knob, w/white indicator	φ16x14.8mm	3	for VR301-303
061-100016-000ZR	GR partition post	PN:BCMS-8 L=	5	
063-181326-001ZR	GR PLATE(MODEL 15/	174.5x133.4	1	
064-161302-000ZR	COVER (MODEL 15) B	6.26"x5.21"x	1	
086-021836-000ZR	GR Power cord for 120V	SPT-2 #18 12 ft+T187	1	
086-021820-001	Power cord for 230V	L=2.0M H05VV	1	
091-000132-000	FUSE / 120V	T6.3A/250V G	1	F1
091-000424-000	FUSE / 230V	VBS UTE 3.15A 250VAC-P	1	F1
074-020018-000	ROCKER SW (POWER)	PN:RF1003-BB4-0	1	POWER SW

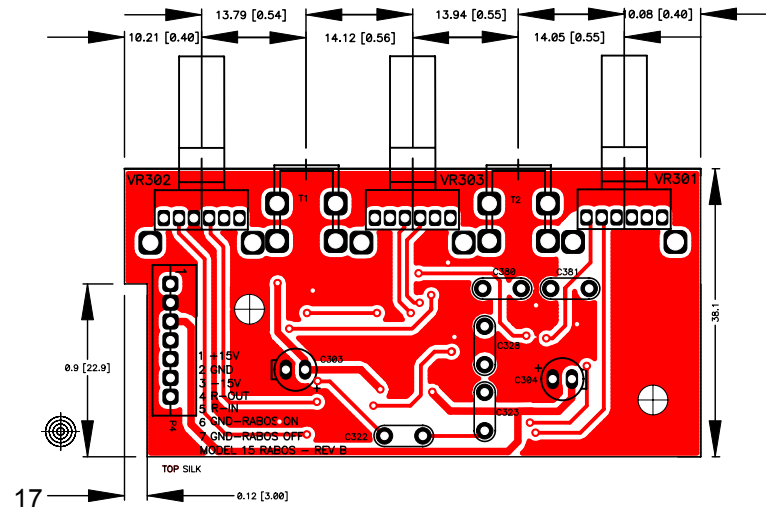
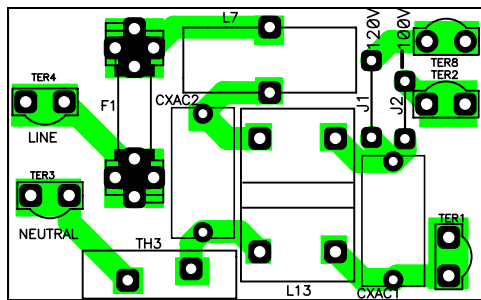
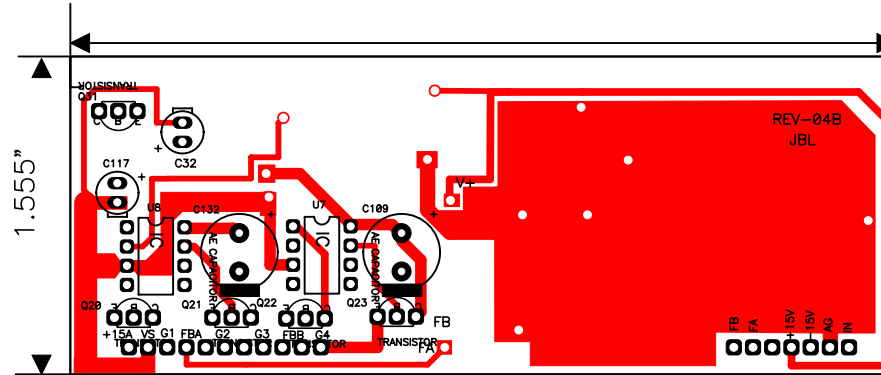
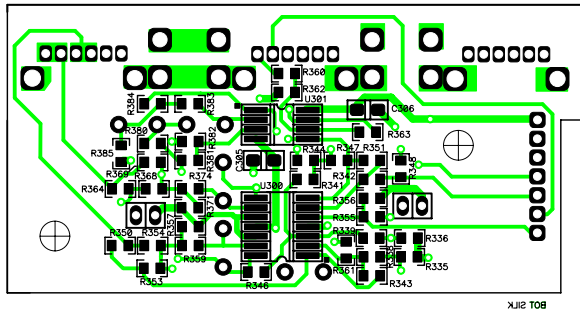
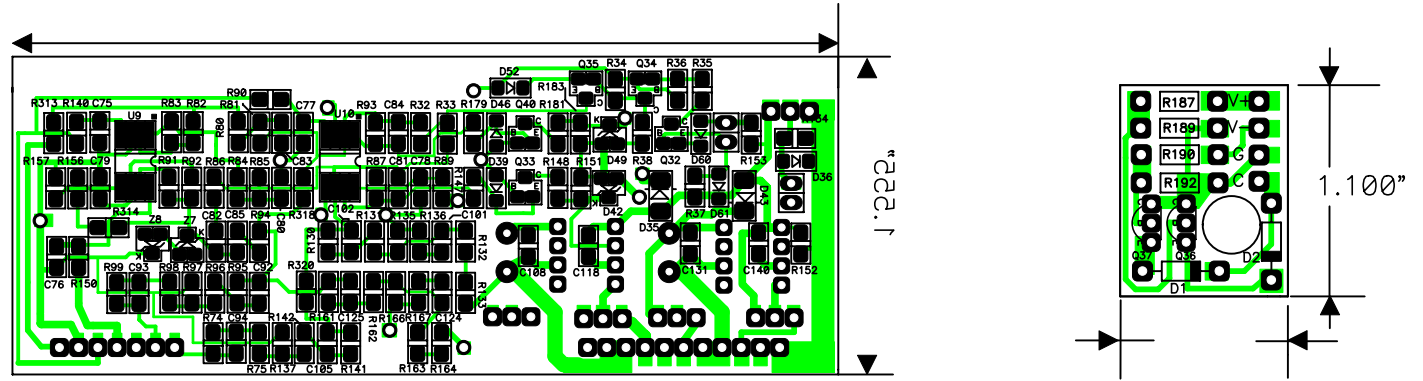

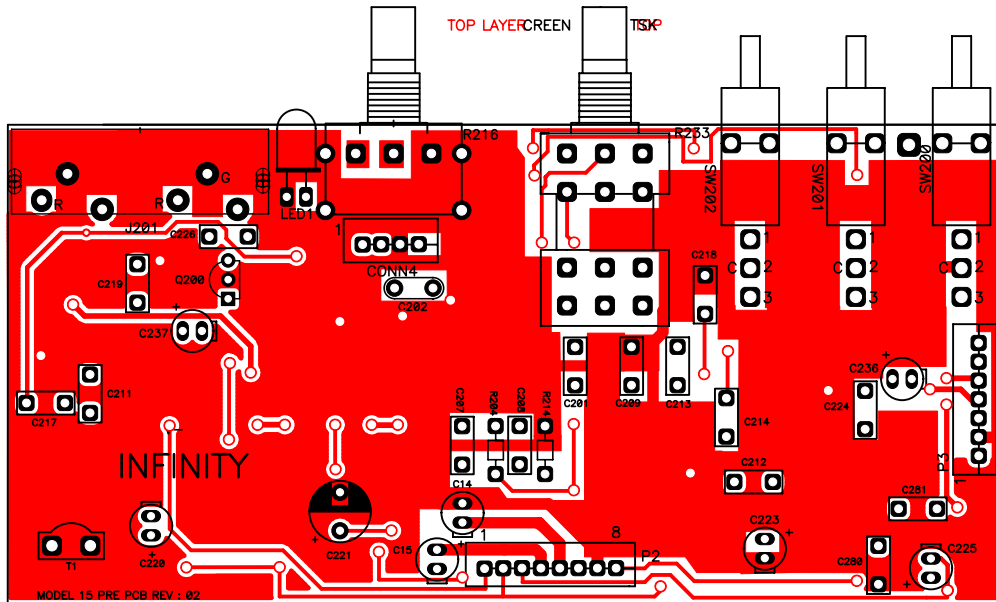
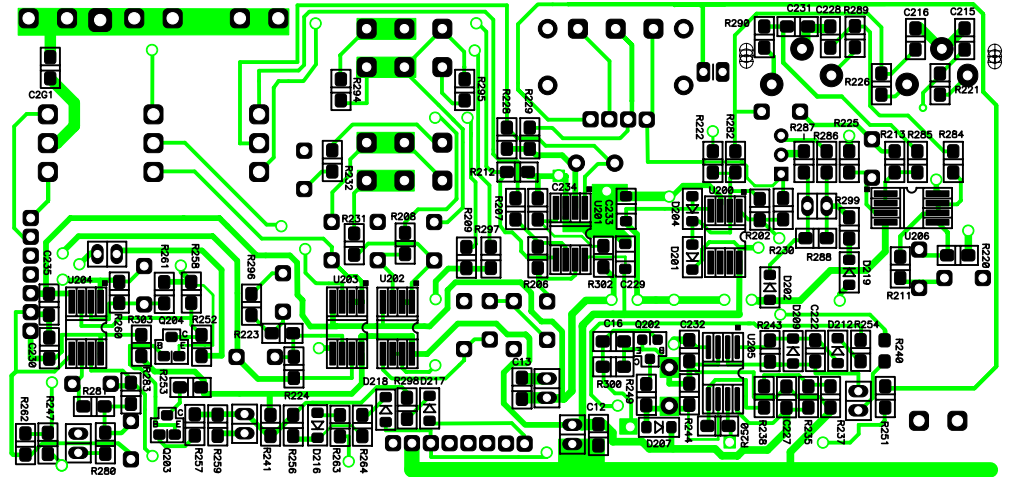

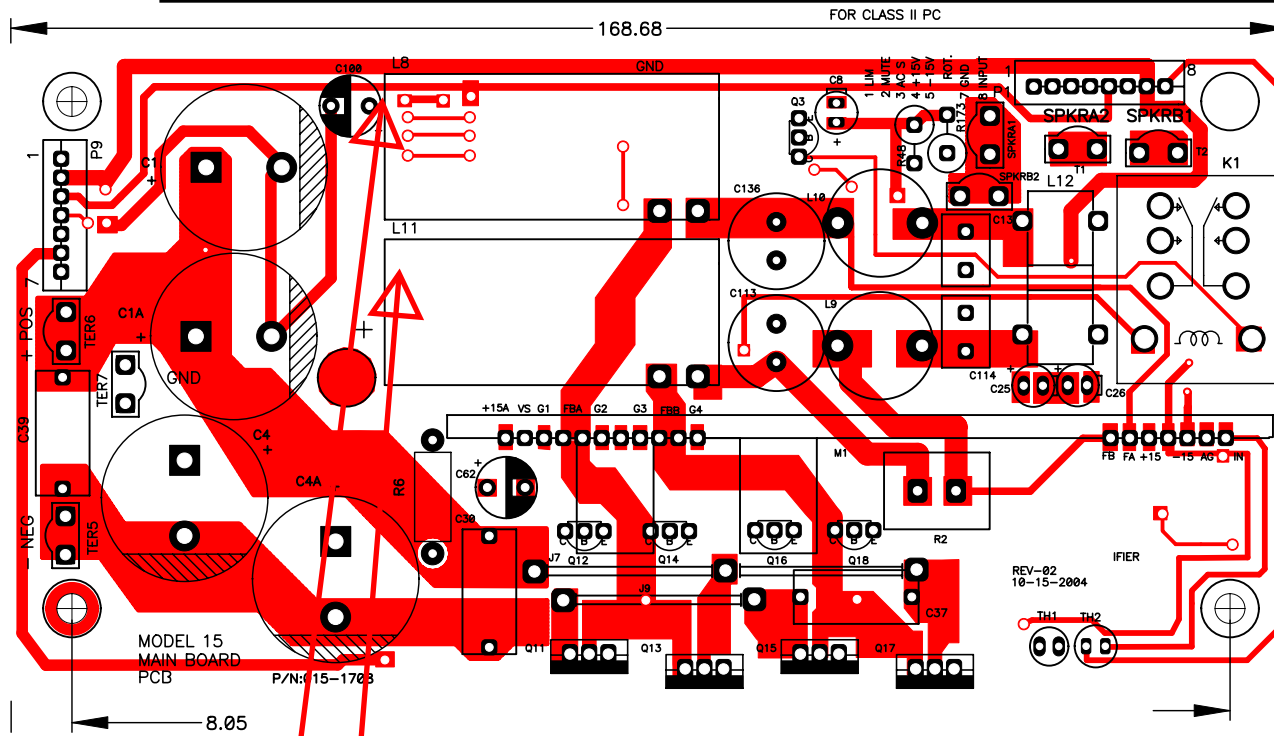

NOTE: DESIGNATORS ARE WRONG
 (SWAPPED) FOR L8 AND L11.
 BOTH DRAWING AND ACTUAL PCB
 ON MODEL FIFTEEN

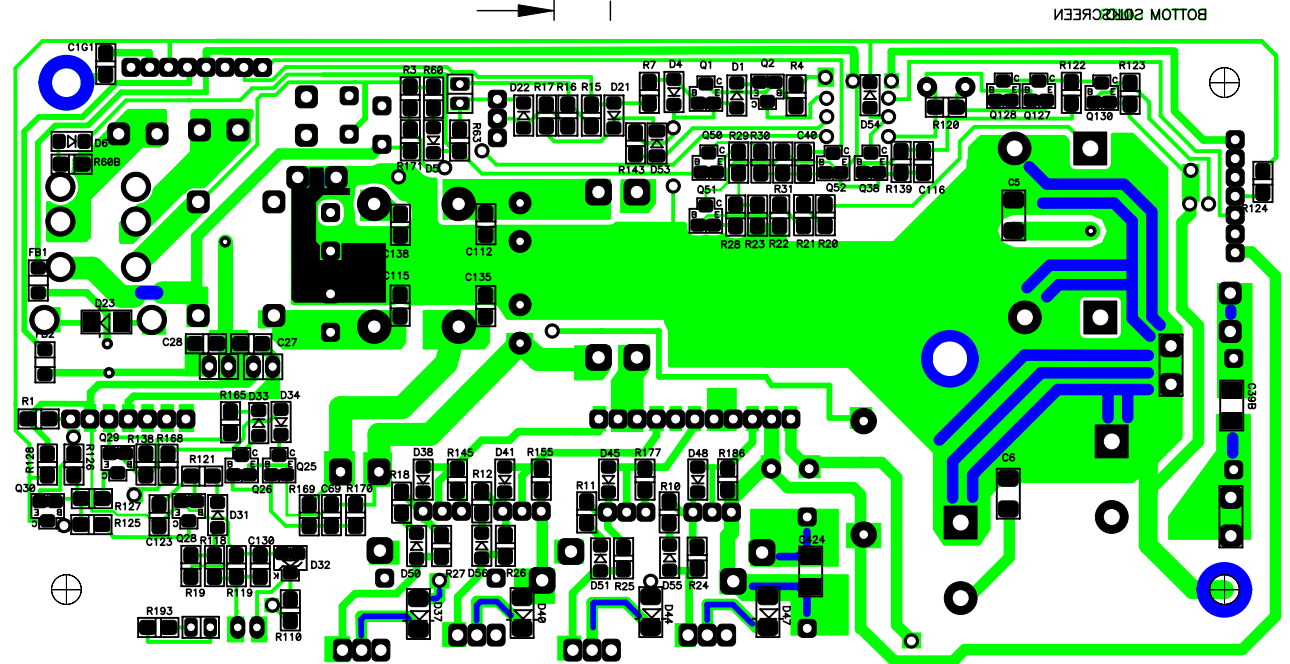

Integrated Circuit Diagrams

OPAMP, QUAD 14P TL074

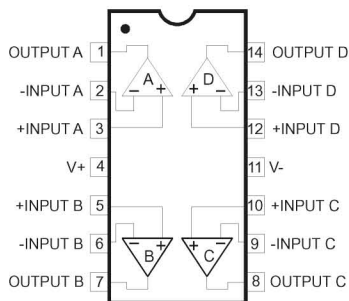

TOP100-4
TOPSwitch Family
Three-terminal Off-line PWM Switch

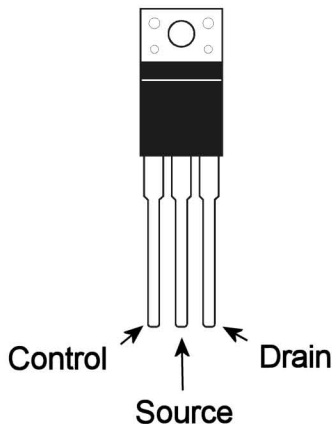

OPAMP, DUAL 8PIN
TL072

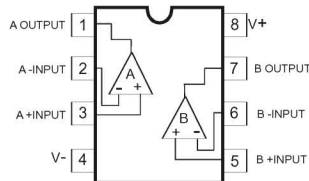

IR2111

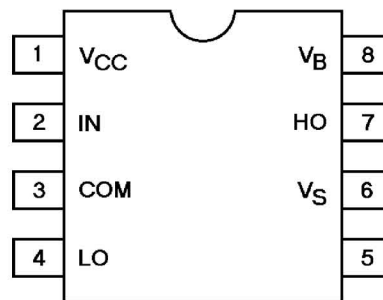

TRANS, NPN T0220
TIP31C

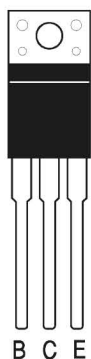

MOSFET, T0220
IRFB23N20D

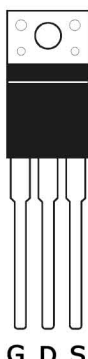

IR2111
Functional Block Diagram

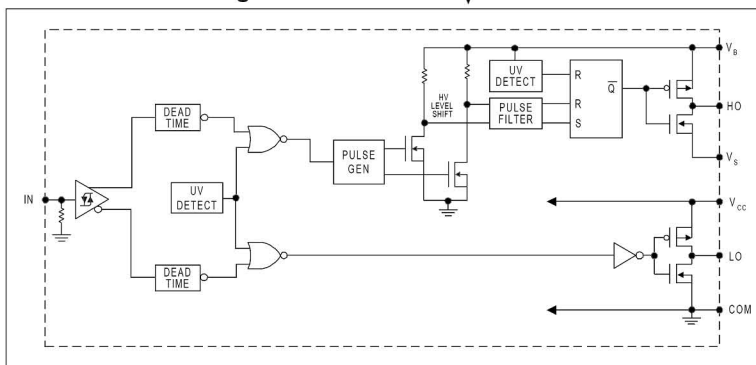

TRANS NPN MPSW06,
MPS2222A, 2N5551

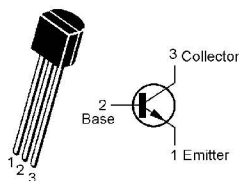

TRANS PNP
MPSW56, 2N2709A,
2N5401

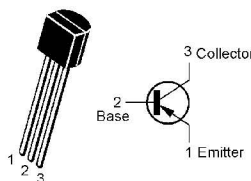

JFET
J111

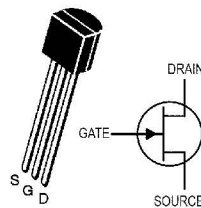

- * MMBT2907A
- * MMBT3904LTI SOT23,
- * MMBT3906LTI SOT23,
- DTC114TK SMT3
- * MMBT5401 LTI
- * MMBT5551

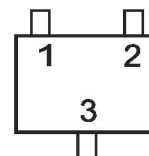

- 1) Emitter
- 2) Base
- 3) Collector

* PREFIX MAY BE "FMMT"

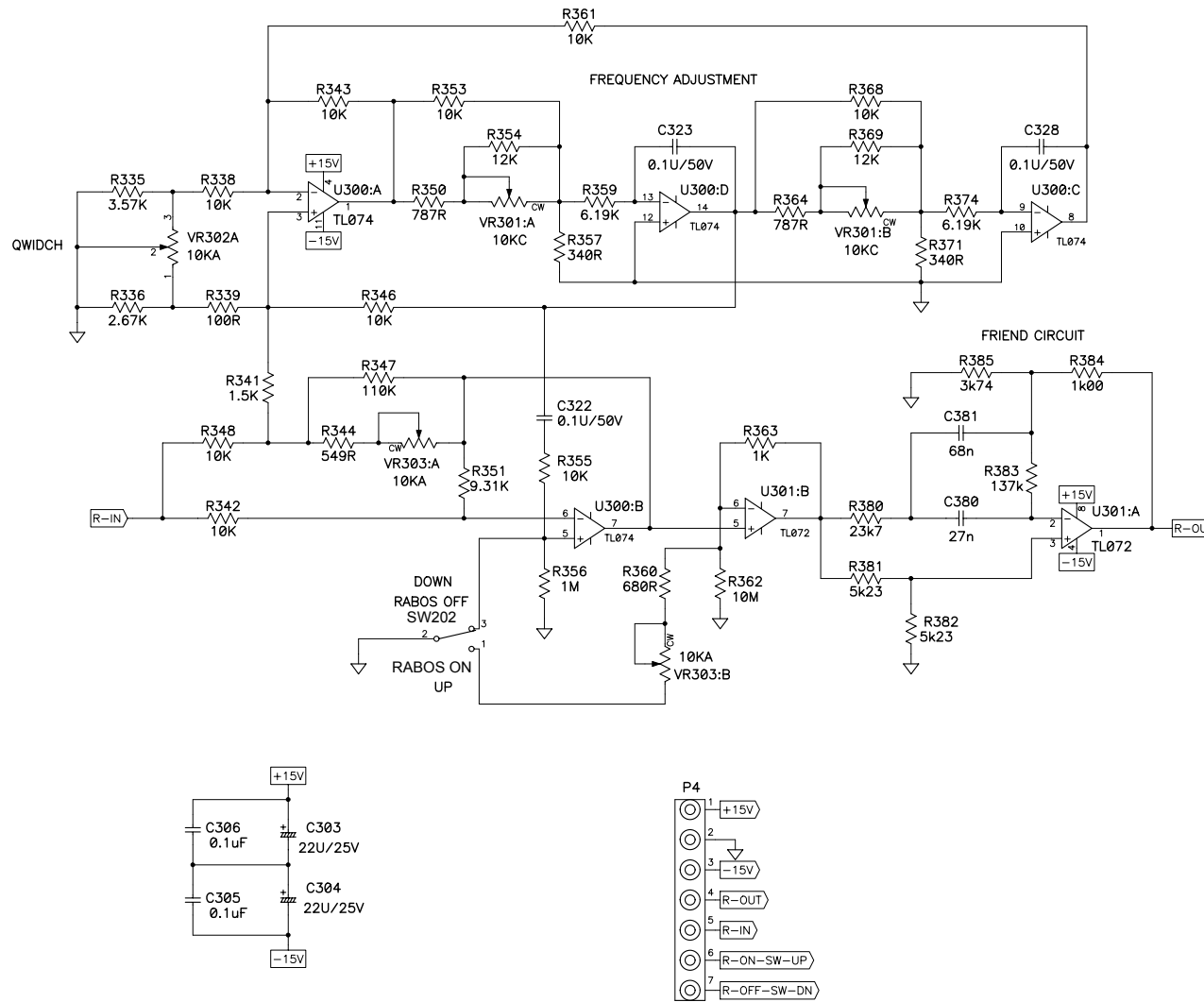

Rev:	Notes:	Date:	Rev:	Notes:
X0	Cascade Model 15	05/03/2005		
X1	Additions and corrections	05/09/2005		
X2	Designator and value changes	06/06/2005		
X3	Designator and value changes	07/06/2005		

Draw by	Designed by	Checked by	Approved By

Harman Consumer Group	
:	TBD
Model no:	Cascade Model-15
Sch name:	Model-15-Sub-081205.sch
Issue no:	
Date:	08/12/05
Sheet:	4 OF 4 Rev: X6
Size:	A2 Author: D.RUSSELL

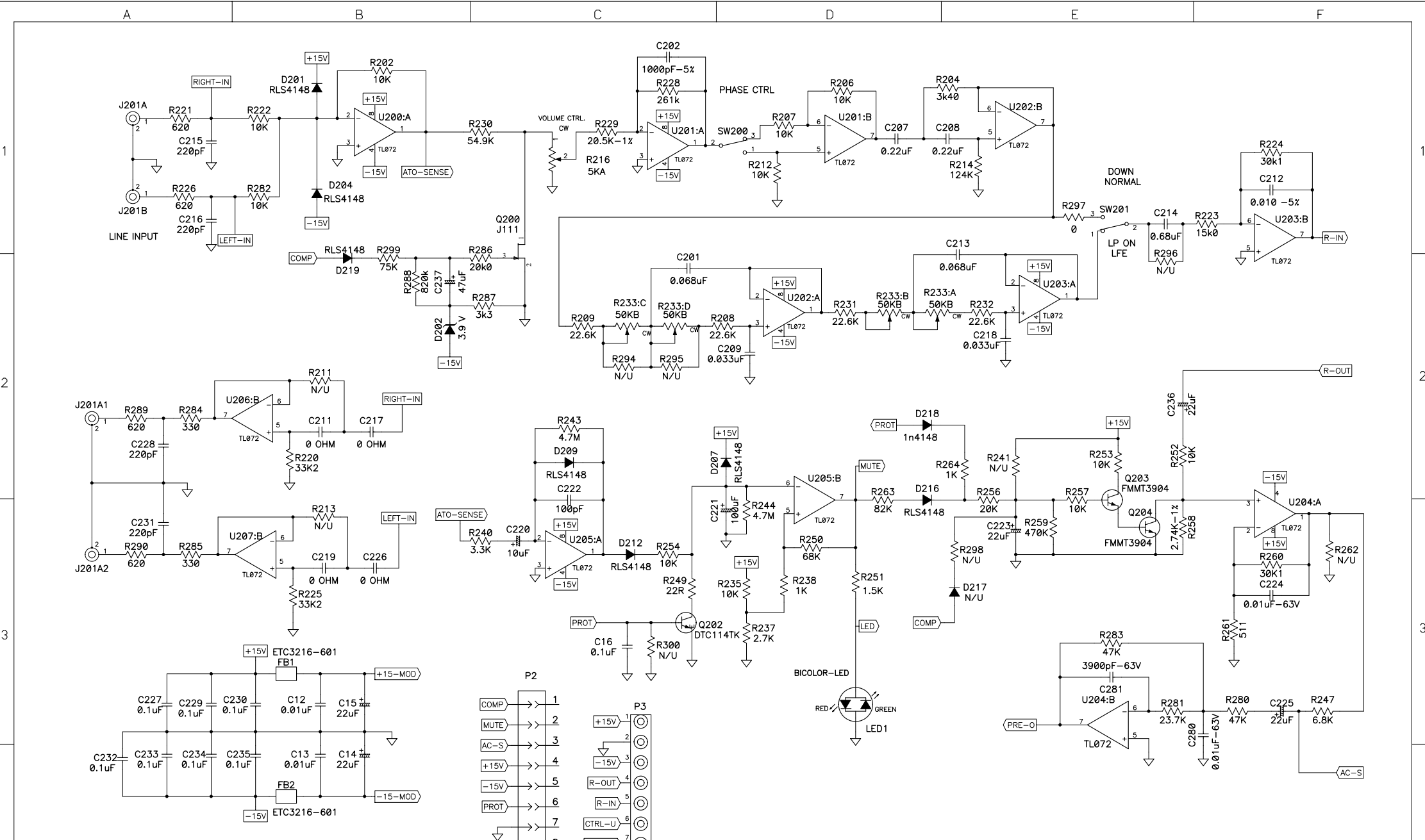

Rev:	Notes:	Date:	Rev:	Notes:
X0	Cascade Model 15	05/03/2005		
X1	Additions and corrections	05/09/2005		
X2	Designator and value changes	06/06/2005		
X3	Designator and value changes	07/06/2005		

Draw by	Designed by	Checked by	Approved By

Harman Consumer Group			
: TBD			
Model no: Cascade Model-15			
Sch name: Model-15-Sub-081205.sch			
Issue no:			
Date: 08/12/05			
Sheet: 2 of 4 Rev: X6			
Size: A2 Author: D.RUSSELL			

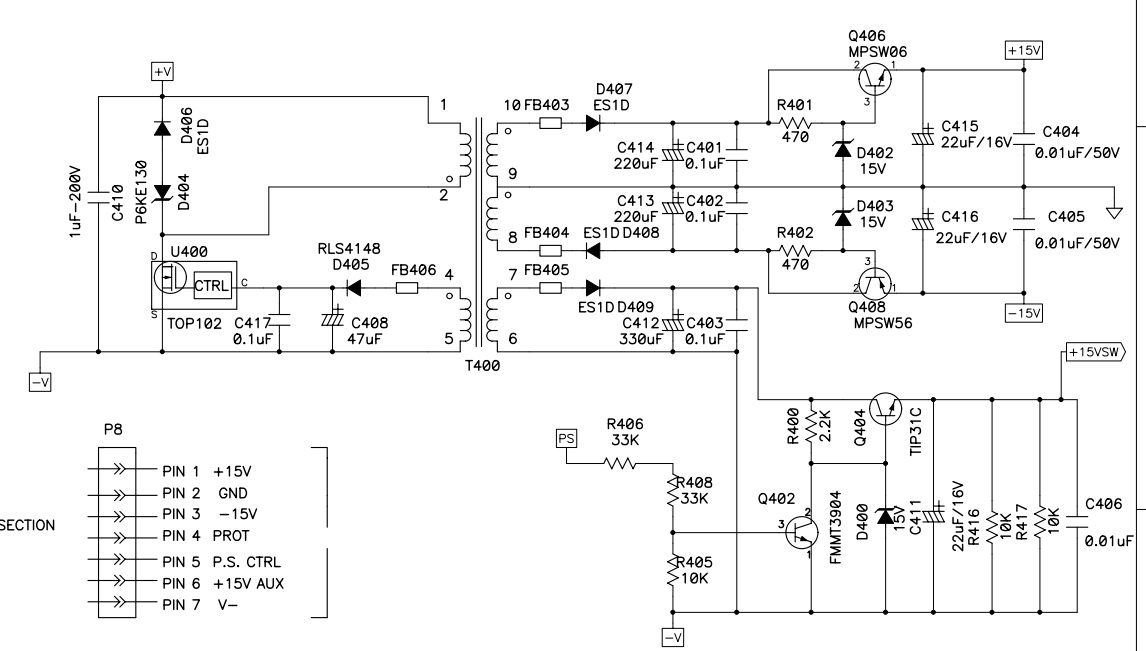
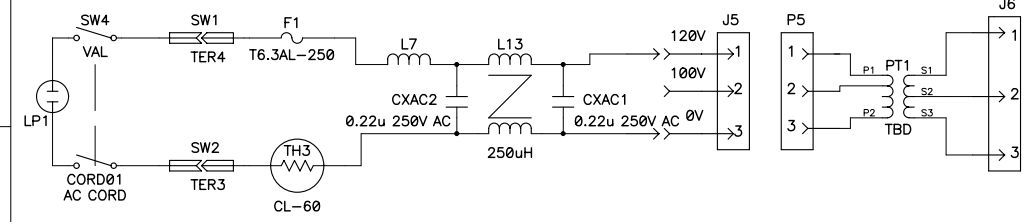
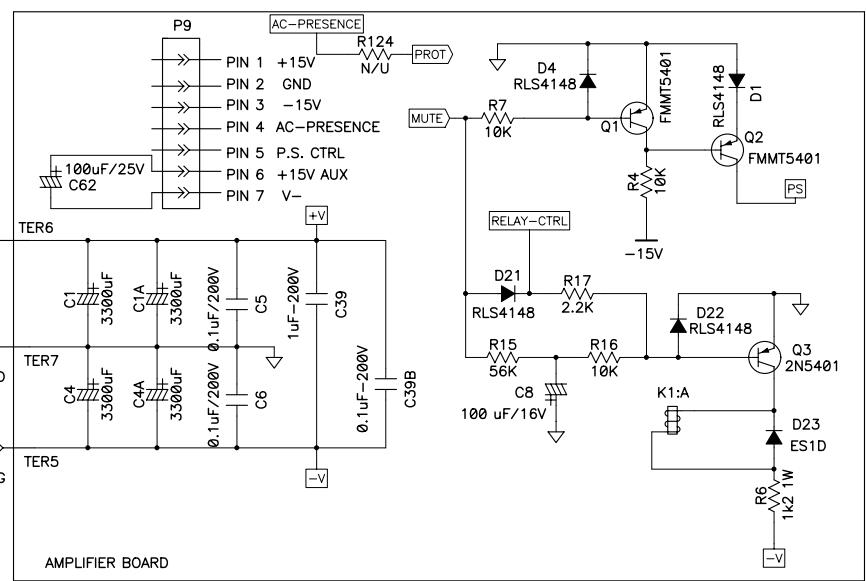
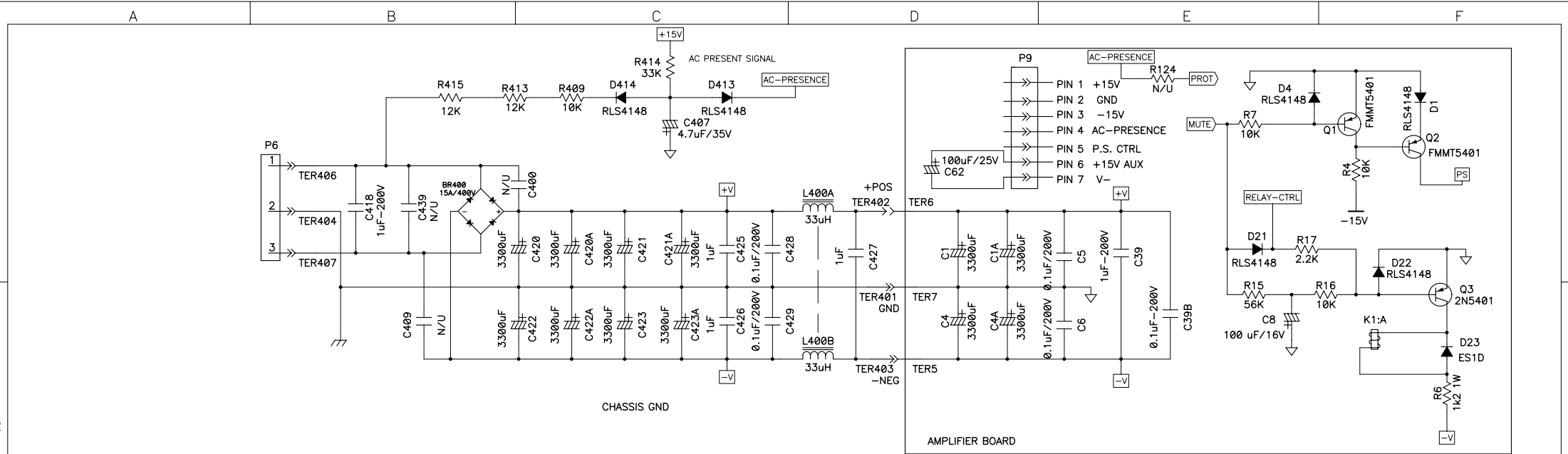

Rev:	Notes:	Date:	Rev:	Notes:
X0	Cascade Model 15	05/03/2005		
X1	Additions and corrections	05/09/2005		
X2	Designator and value changes	06/06/2005		
X3	Designator and value changes	07/06/2005		
X4	Value changes for PV release	08/01/2005		

Harman Consumer Group			
Draw by	Designed by	Checked by	Approved By
: TBD			
Model no:		Cascade Model-15	
Sch name:		Model-15-Sub-081205.sch	
Issue no:			
Date: 08/12/05			
Sheet: 1 of 4 Rev: X6			
Size: A2		Author: D.RUSSELL	

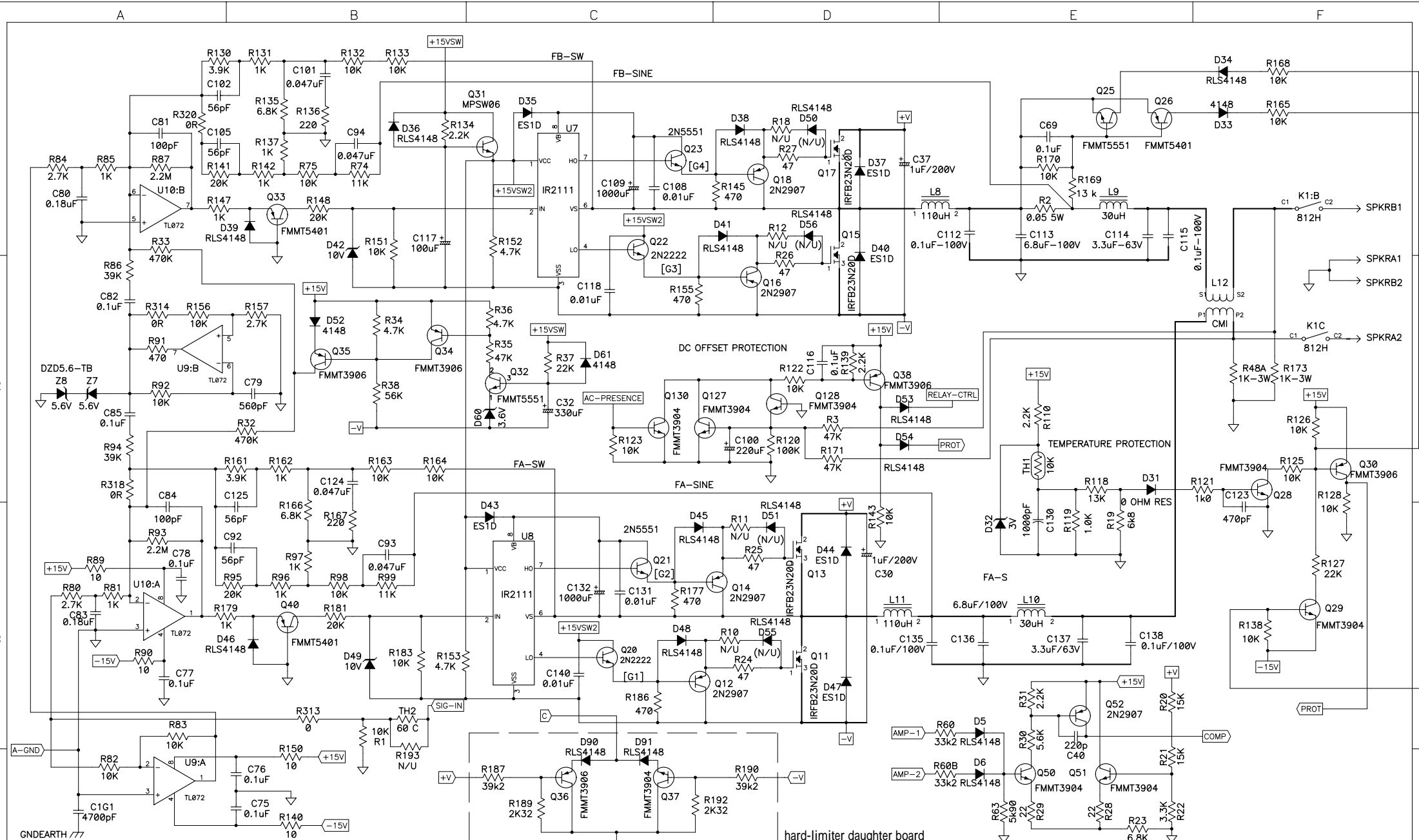

Rev:	Notes:	Date:	Rev:	Notes:
X0	Cascade Model 15	05/03/2005		
X1	Additions and corrections	05/09/2005		
X2	Designator and value changes	06/06/2005		
X3	Designator and value changes	07/06/2005		
X6	Addition of hard-limiter daughter board and R63 value change	08/12/2005		

Draw by	Designed by	Checked by	Approved By	Harman Consumer Group
				TBD
				Model no: Cascade Model-15
				Sch name: Model-15-Sub-081205.sch
				Issue no:
				Date: 08/12/05
				Sheet: 3 of 4 Rev: X6
				Size: A2 Author: D.RUSSELL